

# *Onyx 90 Media Cutter*

## Owner's Manual

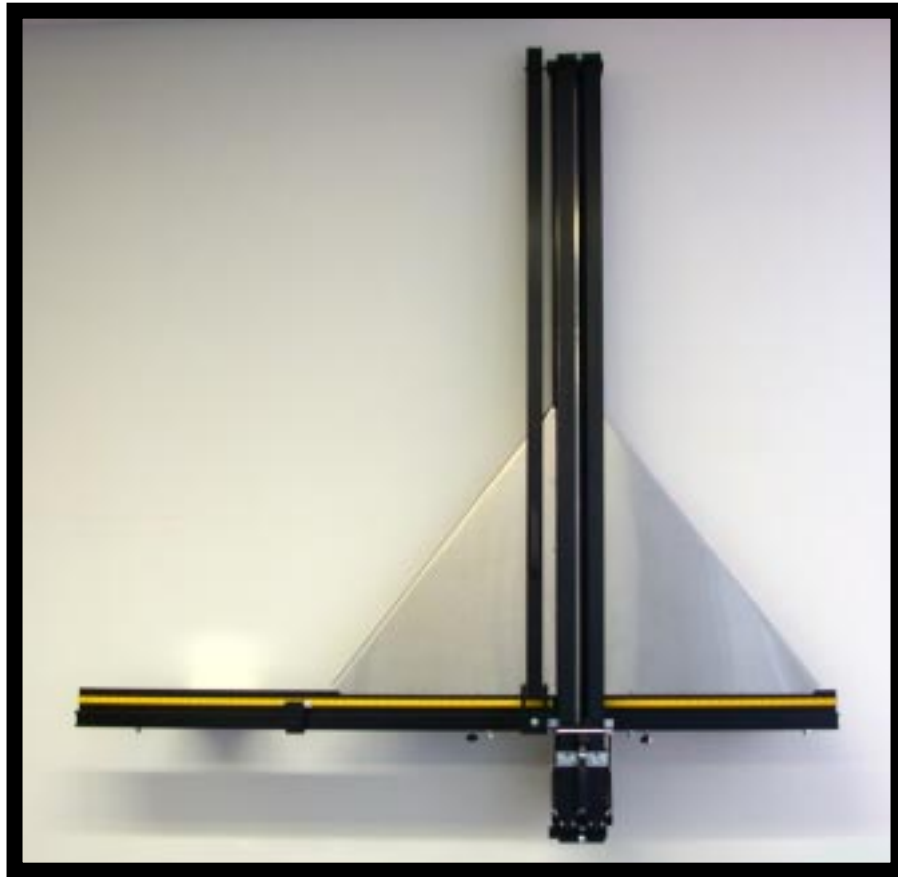

### **Know Your Onyx 90 Media Cutter**

*Professional Picture Frame Equipment*

*441 South Whitted Street*

*Hendersonville, North Carolina 28739*

# Onyx 90 Media Cutter

## Congratulations

and thank you! You have just purchased the best wall mounted media cutter in the world. The Onyx 90 will provide you with many years of dependable service with only minimal maintenance.

We know you are anxious to begin using it. But before you do anything, please take the necessary time to read and understand this manual. It will answer a lot of your questions and avoid possible problems.

## Table of Contents

1.0	Safety Precautions & Recommendations.....	Page 3
2.0	Registration & Warranty.....	Page 3
3.0	Know Your Machine.....	Page 3
4.0	Installation of the Onyx 90.....	Page 5
5.0	Cutting Tool Holders.....	Page 9
6.0	Using the Onyx 90.....	Page 9
7.0	Routine Maintenance.....	Page 13
8.0	Adjustments.....	Page 13
9.0	Troubleshooting.....	Page 17

# Onyx 90 Media Cutter

## 1.0 Safety Precautions & Recommendations

When using the Onyx 90, basic safety precautions should always be followed to eliminate the risk of damage or injury to persons or materials.  
Wear safety glasses, gloves and protective clothing.  
Use caution when using, transporting, storing or disposing of dangerous objects, such as cutting tools, glass, etc.  
Make sure the machine is mounted securely by following the installation instructions.  
Keep the machine and the work area around the machine clean.  
Never place your hand or fingers behind the media clamp.

**For what it is worth – be safe!**

## 2.0 Registration & Warranty

Your Onyx 90 has a 5 year manufacturer's warranty from the date of purchase. Please take a moment to fill out and mail the enclosed warranty card. Proof of purchase must be submitted with warranty card.

Professional Picture Frame Equipment warrants the Onyx 90 to be free from defects in workmanship and parts for 5 years from date of purchase. Professional Picture Frame Equipment warrants it will repair or replace any defective parts. The Onyx 90 must be subjected to normal use and service. A return merchandise authorization (RMA) must be requested from Professional Picture Frame Equipment before returning.

This warranty is in lieu of all other agreements. Professional Picture Frame Equipment is not liable for any damages or losses, incidental or consequential, direct or indirect, arising out of the use of this product.

## 3.0 Know Your Machine

### 3.1 Diagram of Parts

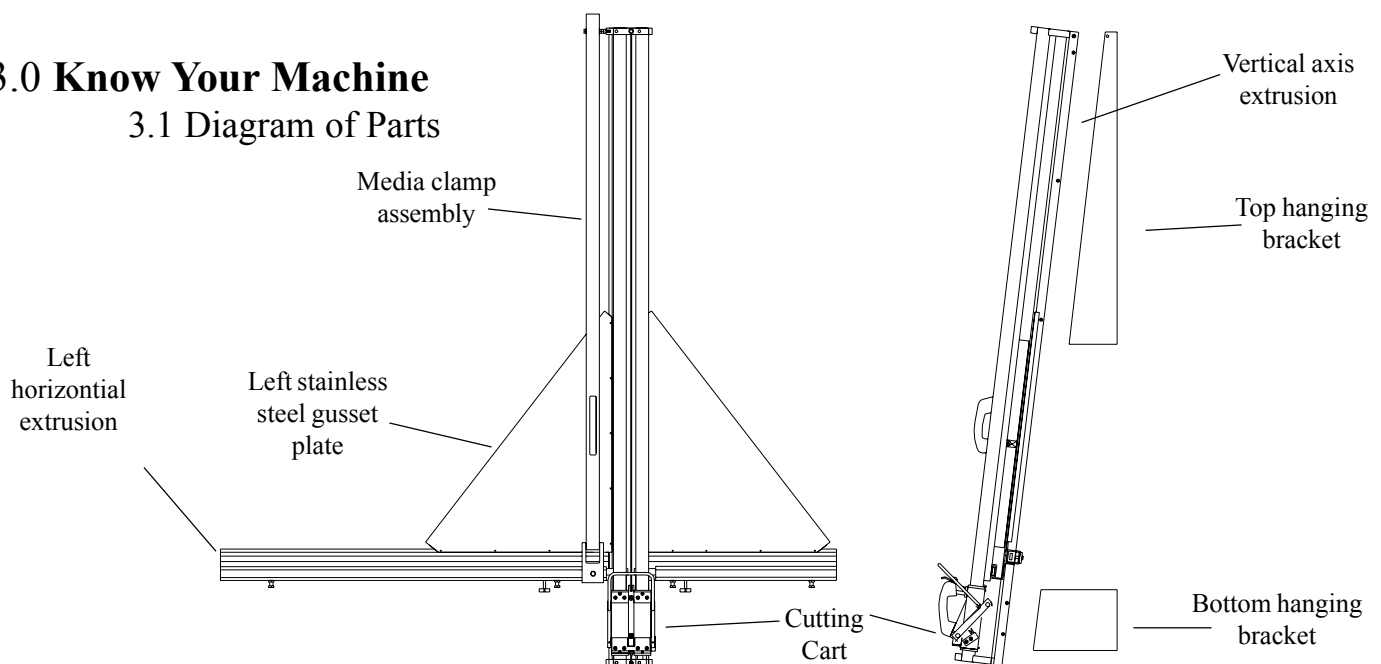

# Onyx 90 Media Cutter

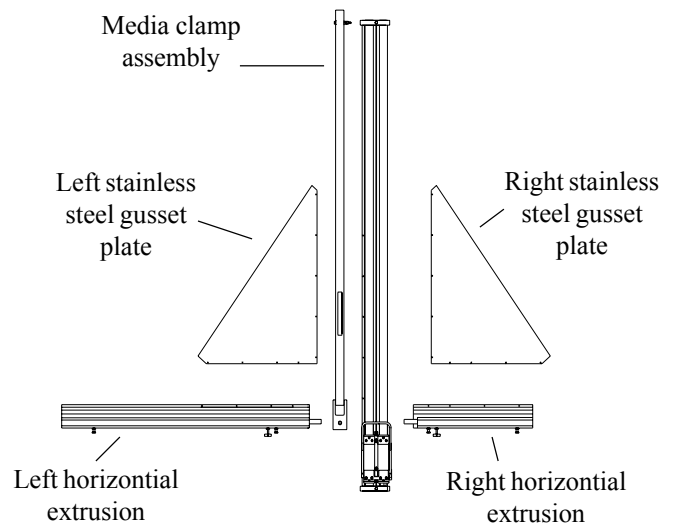
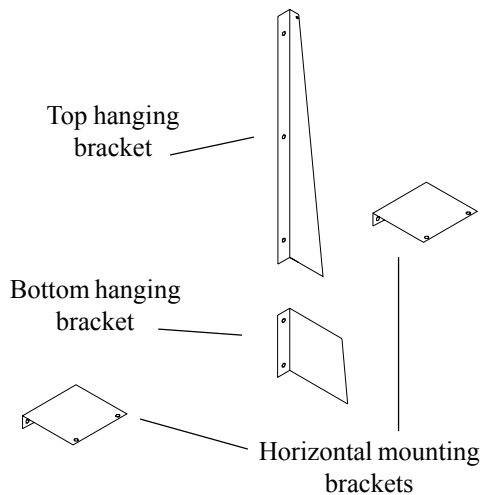

## 3.2 List of Parts That Were Shipped

Box 1 (Large cardboard shipping box)  
 Media Clamp Assembly  
 Bearing-tubes and Cart Assembly Unit  
 Left Horizontal Extrusion  
 Vertical Axis Extrusion

Box 2 (Small cardboard shipping box)  
 Owners Manual  
 Stainless Steel Gusset Plates (2)  
 Right Horizontal Extrusion  
 Vertical Wall Mounting Brackets (2)  
 Horizontal Wall Mounting Brackets (2)  
 Hardware Packets (4)  
 Tooling Package  
 Glass Cutting Tool Holder  
 Mat Board Cutting Tool Holder  
 Plastic Cutting Tool Holder  
 Production Stop  
 Spare Mat Cutting Blades

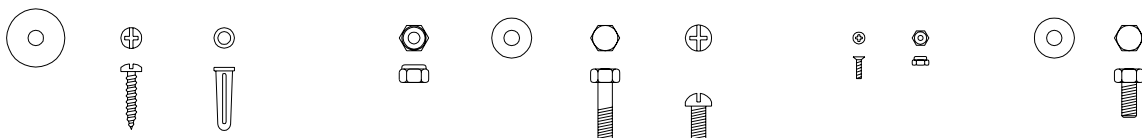
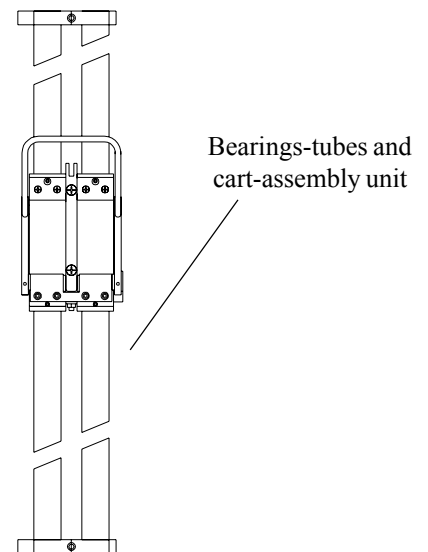

# Onyx 90 Media Cutter

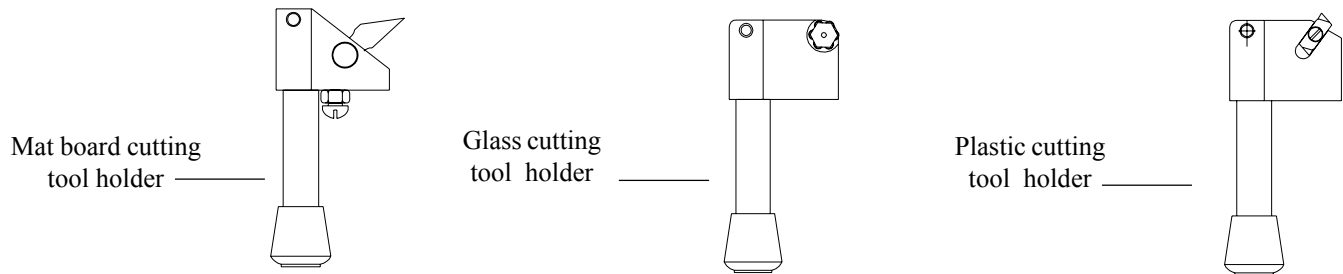

## 4.0 Installation

### 4.1 Tools you will need to collect before beginning

An assistant

Ladder

Level, preferably at least 3 ft long

Electric drill/screwdriver with either 1/4 masonry drill bit or 1/8" wood bit

Hammer

Phillips head screwdriver, large

Tape measure

Straightedge, 36" or longer

Builder's square

Pencil

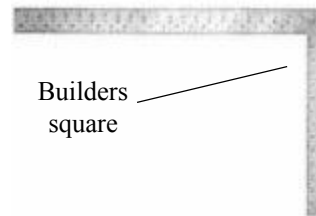

### 4.2 Step-By-Step Instructions

These written instructions are provided - video, which requires Windows Media Player is on the Internet. <http://framingsupplies.com/>

**First: Determine on what type of wall you will be installing your machine - wood or masonry?**  
Follow appropriate instructions.

**Second: Determine your personal working height.**

### 4.3 Cutting Bed Elevation Chart

Generally speaking, most framers determine the cutting bed height (the height that your media rests on) of their machine as influenced by two factors: employee's work height, and the weight and size of the materials to be placed onto the cutting bed of the Onyx 90. For example, if you are tall, then mounting the machine higher may be better for you. If you process a lot of large sized glass, acrylic, or other sheet materials, you may find a lower cutting bed height better. Always think of safety when lifting and process

# Onyx 90 Media Cutter

ing your materials.

From the following chart you may choose the cutting bed height suited for you. Once you have determined your cutting bed height, this chart will indicate the measurement of the top hole of the top hanging bracket.

The following measurements are measured vertically, from the floor up.

<b>Cutting Bed Height</b>	<b>Top hole of the top hanging bracket</b>
33 inches above the floor	93 inches above the floor
32 inches above the floor	92 inches above the floor
31 inches above the floor	91 inches above the floor
30 inches above the floor	90 inches above the floor
29 inches above the floor	89 inches above the floor
28 inches above the floor	88 inches above the floor
27 inches above the floor	87 inches above the floor
26 inches above the floor	86 inches above the floor
25 inches above the floor	85 inches above the floor

*Note: If you have an 8' ceiling, the maximum cutting bed height will be 31" from the floor.*

#### 4.4 Installation on a Masonry Wall

1. Use a 1/4" masonry drill bit to drill all holes into the wall.
2. Insert blue plastic anchors into a drilled holes in the wall.
3. Follow all other instructions for a wood wall installation.

#### 4.5 Installation on a Wood Wall

##### 4.5.1 Mounting the Vertical Mounting Brackets

1. Remove protective polyethylene film from all the stainless steel parts.
2. Locate a vertical stud on the wall.
3. Using a level draw a vertical line 94" in length on the wall to the floor.
4. Drill a 1/8" pilot hole on the line 91" from the floor. (See above chart to determine your personal working height.)
5. Using the top hanging bracket as a template, center the top hole of the top hanging bracket over the drilled hole on the line. Trace two circles for the two lower holes.

# Onyx 90 Media Cutter

6. Remove the bracket/template and drill the two lower 1/8" pilot holes.
7. Place the top hanging bracket over the holes and using the screws and washers from the bracket hardware package, mount the top hanging bracket in all three places.
8. Measure 29 1/4" down from the *bottom* of the top hanging bracket and place a mark on the vertical line.
9. Place the *top* of the bottom hanging bracket on that measurement line – the one you just marked at 29 1/4".
10. Using the bottom hanging bracket as a template, center the two holes in the bottom hanging bracket over the vertical line.
11. Trace the two holes with a pencil.
12. Remove the bottom hanging bracket / template, and drill the two 1/8" pilot holes.
13. Place the bottom hanging bracket over the holes and using the screws and washers from the bracket hardware package, mount the bottom hanging bracket to the wall.
14. Check to verify that the top and bottom hanging brackets are in line with each other and plumb.

## 4.5.2 **Mounting the Vertical Axis Extrusion**

1. Place the vertical axis extrusion with the two flanges on the top bracket and insert the safety screw and nut. The screw is 1/4-20 X 1 1/2" long.
2. Lift and situate the vertical axis extrusion so that the flanges on the back of the vertical axis extrusion straddle the top and bottom brackets.
3. Lightly tighten the five screws on the vertical axis extrusion. There will be a further adjustment later.
4. Retrieve the left horizontal extrusion – it is marked.
5. Attach the left horizontal extrusion to the left mounting bracket. Left and right horizontal mounting brackets are identical.
6. Place the left horizontal extrusion onto the vertical axis extrusion. Use two 1/4-20 X 2" hex head screws, washers and locking nuts to make the attachment.
7. Attach the left stainless steel gusset plate to the left horizontal extrusion and the vertical axis extrusion using the nine #4 x 40 flat head stainless steel screws and nuts.
8. Attach the left horizontal mounting bracket to the wall. Make sure the bracket is perpendicular to the wall.
9. Place the right horizontal extrusion onto the vertical axis extrusion. Use two 1/4-20 X 2" hex head screws, washers and locking nuts to make the attachment.
10. Attach the right stainless steel gusset plate to the right horizontal extrusion and the vertical axis extrusion using nine #4 x 40 flat head stainless steel screws and nuts.
11. Attach the right horizontal extrusion wall mounting bracket to the wall. Again, make sure the bracket is perpendicular to the wall.



# Onyx 90 Media Cutter

## 4.5.3 Cutting Bed Adjustment

In order for the machine to work properly, the cutting beds must be in line. When you stand alone the side the Onyx90, look down the cutting beds, where the left and right cutting beds attach to the vertical axis extrusion, the cutting beds must not be bowed either towards the wall or bowed away from the wall. Everything must be in line. This next adjustment will do that.

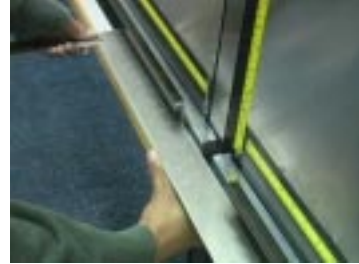

1. Loosen the four bottom-most screws located on the back of the vertical axis extrusion.
2. Using a straightedge placed against the front of the left and right horizontal extrusions, push or pull as necessary to straighten and remove any gap between the straight edge and the horizontal extrusions.
3. While maintaining the pushing/pulling action, have an assistant tighten the four bottom-most screws located on the back of the vertical axis extrusion.



## 4.5.4 Mounting the Bearing-tubes and Cart-assembly Unit

1. Place the bearing-tubes and cart-assembly unit onto the vertical axis extrusion. The top and bottom of this unit will fit precisely onto the machined surfaces of the vertical axis extrusion.

2. Attach the bearing-tubes and cart-assembly unit

with the four 5/16-18" X 3/4" hex screws and washers provided.

## 4.5.5 Mounting the Media Clamp Assembly

2. Locate the 1/4-20 tapped hole in the top mounting bracket of the bearing-tubes and cart assembly unit.
3. Insert the 1/4-20 x 2 3/4" screw of the top mat clamp assembly into the tapped hole in the top mounting bracket of the bearing-tubes and cart-assembly unit. Tighten the 1/4-20 x 2 3/4" screw into the hole and jam the nut to secure.
4. Attach the bottom of the media clamp assembly to the T-nut in the left horizontal extrusion using 1/4-20 x 1" screw and lock washer.
5. Adjust the media clamp assembly so that it is the same distance from the vertical axis extrusion at the top and bottom. When the distances are same, tighten the screw to the T-nut.
6. You have completed the assembly and mounting of your new Onyx 90 Media Cutter.
7. Double check to make sure all screws and nuts are tight.

# Onyx 90 Media Cutter

## 5.0 Cutting Tool Holders

A word about safety – razor blades, plastic cutting tools and glass wheels can all cut you – be careful when handling them.

### 5.1 Plastic Cutting Tool Holder

Plastics up to 1/4" thick can be scored and fractured on your Onyx 90 machine. The plastic cutting tool holder utilizes a double-ended carbide insert to score your plastic media. This carbide insert provides an extremely durable tool, lasting many thousands of cuts. Warning - this carbide insert is very hard and subject to breakage if dropped.

5.1.1 To remove carbide insert, remove the slotted machine screw located in the center of the insert with a small screwdriver.

5.1.2 The carbide insert has two ends. Rotate end for end (if you haven't done so previously) and replace the carbide insert in tool holder. The carbide insert is captured via a machined slot and can not become misaligned.

5.1.3 Re-insert the slotted machine screw and tighten.

### 5.2 Glass Cutting Tool Holder

The Onyx 90's glass cutting tool incorporates a six-position turret which contains six solid carbide glass cutting wheels. This turret is numbered 1 through 6, giving you means to keep track of the new and used carbide wheels in the turret.

5.2.1 To change to a new wheel, simply loosen the turret retaining screw 1/2 turn and index the turret to the next position.

5.2.2 Align the new wheel so the center of the wheel is aligned with the cross mark on the face of the tool holder.

5.2.3 Tighten the screw.

**Attention:** If the turret retaining screw is loosened more than 1/2 turn, the carbide wheels may fall off the axles and become lost.

### 5.3 Mat Board Cutting Tool Holder

This tool holder is used for cutting mat board, foam board, gator board, sentra, travicel, cardboard as well as many other media.

# Onyx 90 Media Cutter

## 5.4 Changing and Adjusting Blade Depth

**Attention: Use caution during this process so that your hand does not come in contact with the razor blade.**

### 5.4.1 Changing the Blade

1. Loosen the adjustable set screw on the side of the mat board cutting tool holder
2. Discard the old blade safely.
3. Place a new blade in the mat board cutting tool holder and tighten the set screw with the 1/4" allen wrench provided.

### 5.4.2 Adjusting blade depth

There is a phillips head set screw and jam nut located on the back of the mat board cutting tool holder which maintains proper blade cutting depth. This depth is adjusted at the factory and may never require adjustment.

## 5.5 Replacement Blades

The Onyx 90 uses economical blades – Part #PPFE-0024.

## 5.6 Changing from one kind of tool holder to another

Once you have practiced a few times, we are sure you will agree that the Onyx 90's tool interlock system allows you very fast tool change.

### 5.6.1 To insert a tool holder into the machine

1. Hold the tool holder by the handle and place the tool onto the grooved pivot arm.
2. Notice on the tool holder there is a locking pin located on the bottom front of the tool holder. This locking pin must engage or fit into a matching groove on the pivot arm.
3. Slide the bottom of the tool holder pins into the grooved pivot arm, **pull back and down on the spring loaded handle**, it will lock in place.

**5.6.2 To remove a tool holder from the machine**, lift up on the tool handle and remove the tool.

## 6.0 Using the Onyx 90 Cutting Tools

### 6.1 Cutting Glass

# Onyx 90 Media Cutter

**Attention:** Remember to wear eye protection, gloves and protective clothing when handling glass.

***Do not use the media clamp assembly when cutting glass. That clamp is only used when cutting mat board and plastic.***

- 6.1.1 Place your glass on the left side of your Onyx 90 machine.
- 6.1.2 Place the glass cutting tool holder on the pivot arm.
- 6.1.3 The larger piece of glass should be on the left side of the cut and the smaller piece of glass should be on the right side of the cut.
- 6.1.4 Use either the right or left measuring scale on the horizontal axis extrusions as necessary.
- 6.1.5 Place your left hand on the glass - apply holding pressure.
- 6.1.6 Pull back the handle.
- 6.1.7 Raise the cutting cart to the top edge of the glass.
- 6.1.8 Lower the handle and place the glass cutting wheel on the top edge of the glass.
- 6.1.9 You can now take advantage of one of the Onyx 90's best features. You can vary the amount of pressure needed to make an efficient score just by adding more or less pressure. No global machine adjustment is necessary.
- 6.1.10 With one slow, smooth, continuous motion, pull down the cutting cart past the bottom edge of the glass.
- 6.1.11 You have just "scored" the glass. **Only score glass one time.**
- 6.1.12 After scoring, do not move the glass.
- 6.1.13 With your left thumb, apply slight pressure on the bottom left edge of the glass near the score. With your right thumb, apply **increasing** pressure on the bottom right edge of glass near the score until the glass separates. The break will occur at the bottom of the score line and run up to the top of the score line. The break chases the score.
- 6.1.14 Never apply pressure to the center or the top of the glass because the break may not follow the score.

## 6.2 **Cutting Mat Board**

- 6.2.1 The Onyx 90 will cut to up 5/8" deep. When cutting materials that deep, a sharp blade and successive cuts are necessary. The media clamp can not be used on thicknesses greater than 1/4".
- 6.2.2 The use of the media clamp is not mandatory, but on thin media, it will reduce the chance of media buckling.
- 6.2.3 Where it is deemed necessary to have a fine cut edge, a slip sheet under the cut sheet may be desired.

# Onyx 90 Media Cutter

- 6.2.4 Place the mat board cutting tool holder on the pivot arm.
- 6.2.5 Slide the media to be cut onto the left cutting bed of the Onyx 90.
- 6.2.6 Use the right or left measuring scale as necessary.
- 6.2.7 Engage the media clamp by lifting, pushing forward and lowering the clamp into position.
- 6.2.8 Pull back the handle on the cutting cart until it locks.
- 6.2.9 Raise the cutting cart above the media to be cut.
- 6.2.10 Release the handle using the thumb release.
- 6.2.11 You can now take advantage of one of the Onyx 90's best features. You can vary the amount of pressure needed to make efficient cuts just by adding more or less pressure. No global machine adjustment is necessary.
- 6.2.12 With one slow, smooth, continuous motion, pull down the cutting cart past the bottom edge of the media.
- 6.2.13 Release the media clamp.

## 6.3 Cutting Plastic

- 6.3.1 Onyx 90 will cut fracture sensitive plastic up to 1/4" thick. This includes acrylic, polycarbonate, Plexiglas etc.
- 6.3.2 Place the plastic cutting tool holder on the pivot arm.
- 6.3.3 Slide the media to be cut onto the left cutting bed of the Onyx 90.
- 6.3.4 Use the right or left measuring scale as necessary.
- 6.3.5 Engage the media clamp by lifting, pushing forward and lowering the clamp into position.
- 6.3.6 Pull back the handle of the cutting cart until it locks.
- 6.3.7 Raise the cutting cart to the upper edge of the fracture sensitive plastic.
- 6.3.8 Release the handle using the thumb release.
- 6.3.9 You can now take advantage of one of the Onyx 90's best features. You can vary the amount of pressure needed to make efficient scores just by adding



more or less pressure. No global machine adjustment is necessary.

- 6.3.10 With one slow, smooth, continuous motion, pull down the cutting cart past the bottom edge of the media.
- 6.3.11 **Note:** you will hear a gouging sound of the material.
- 6.3.12 Repeat this procedure two or three times, depending upon density of material being scored.
- 6.3.13 To fracture "or crack" the plastic, raise the cutting cart to the top edge of the plastic.

# Onyx 90 Media Cutter

- 6.3.14 Push in on the plastic fracture swing arm handle. At the same time, align the white rollers with the top edge of the fractured sensitive plastic.
- 6.3.15 Apply increasing pressure to the plastic fracture swing arm handle until you hear the plastic snap. Continue to hold the pressure on the plastic fracture swing arm handle while pulling down the cutting cart past bottom of the fractured sensitive plastic in one slow, smooth continuous motion.
- 6.3.16 Release the media clamp.
- 6.3.17 Remove the plastic from the Onyx90 and separate the two plastic pieces.

## 6.4 Using the Media Clamp

- 6.4.1 The media clamp requires only one hand to operate. Simply lift up the clamp from its rest position and move it towards the media to be clamped.
- 6.4.2 Gravity will pull the clamp downward and securely lock your work against the stainless steel gusset plate.
- 6.4.3 The clamp is released by lifting up the handle and returning the clamp to the resting position.
- 6.4.4 The media clamp has a substance that will hold your media very securely.



## 6.5 Using the Production Stop

The production stop is used when you are making several consecutive cuts of the same dimension. The production stop can be placed on either the left or right horizontal extrusion.

6.5.1 Simply loosen the plastic locking knob and insert the T-nut and production stop into the channel located at the front of either the left or right horizontal extrusion.

- 6.5.2 Rotate the white plastic arm until it is against the measuring scale.

## 7.0 Routine Maintenance

- 7.1 Brush all debris from both the left and right cutting beds.
- 7.2 Make sure all nuts and bolts remain tight.
- 7.3 Do not oil the machine.

## 8.0 Adjustments - should they become necessary – not likely.

- 8.1 Squaring the Machine / making the cutting beds perpendicular to the vertical axis extrusion.

Your Onyx 90 was squared at the factory and should not require you to make any

# Onyx 90 Media Cutter

adjustments. If for some reason you find it necessary to make this adjustment, here are the steps:

Tools Needed; an assistant, builder's square, 7/16" open-end wrench, 9/16" open-end wrench

- 8.1.1 Brush all chips of glass and debris from the cutting beds.

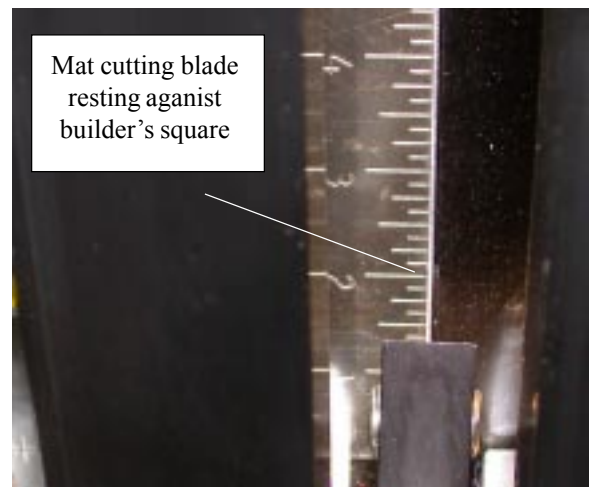
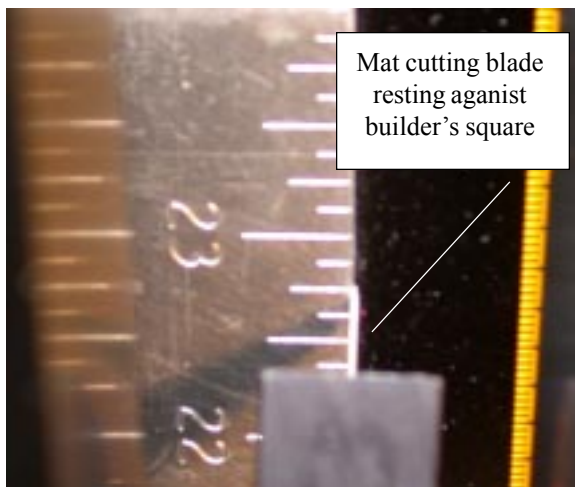

- 8.1.2 There are two plastic knobs that are used to make sure that the cutting beds do not move if someone puts a heavy weight on the ends of the cutting beds. These are used for safety. Loosen the jam nuts and plastic knobs before making any squaring adjustments.
- 8.1.3 Lay the builder's square on the left cutting bed. Put the mat cutting tool in the tool holder. The horizontal portion of the builder's square should be resting on the left cutting bed. The vertical portion of the builder's square should be resting - just touching the mat cutting blade. Without moving the builder's square, raise the cutting cart to the top of the vertical portion of the builder's square. The distance from the blade to the builder's square must be the same at the top and bottom throughout the cutting cart's travel. If there is a gap at the top of the builder's square/blade intersection, then you must loosen the jam nut on the left side of the left horizontal extrusion. Tighten the 3/8" bolt slightly until the gap disappears. Tighten the jam nut.
- 8.1.4 If there is a gap at the bottom of the builders square/blade intersection, then you must square the left cutting bed the other direction. Loosen the jam nut on the left side of the left horizontal extrusion. You must loosen the 3/8" bolt slightly. This will change the gap. The gap must be the same at the top and bottom of the builder's square throughout the cutting cart's travel. Tighten the jam nut. You have completed squaring the left horizontal cutting bed.

# Onyx 90 Media Cutter

- 8.1.5 To square the right cutting bed, place the builder's square on the left cutting bed and slide the builder's square over to the right cutting bed. There should be no gap under the builder's square on the right cutting bed. If there is a gap under the builder's square on the right cutting bed, loosen the two jam nuts on the right horizontal extrusion. Adjust the two 3/8" bolts to make the surface of the right cutting bed flush with the bottom of the builder's square. The builder's square should slide from left-to-right and right-to-left without hitting either cutting beds. If the builder's square hits the left or right cutting bed, you will need to adjust the elevation of the innermost bolt on the right cutting bed. Adjust the 3/8" bolt as needed so that the builder's square will travel from left-to-right and right-to-left without hitting either cutting bed. Tighten both the right cutting bed jam nuts.
- 8.1.6 Finger tighten the plastic knobs.

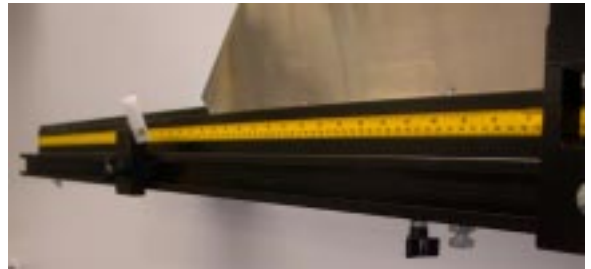

## 8.2 Calibration of the Measuring Tape Scales

The horizontal and vertical measuring tape scales have been set at the factory. If for some reason you find it necessary to make this adjustment, here are the steps.

- 8.2.1 We have secured the measuring tape scales using double-stick adhesive tape applied at the outside ends of the measuring tape scales.
- 8.2.2 Using a small screwdriver, slide it under the measuring tape scale and gently pull away the measuring tape scale from the extrusions.
- 8.2.3 Position the measuring tape scale where you feel it should be by sliding it in the extrusion.
- 8.2.4 Once in position, lower the leading edge of the measuring tape scale and burnish it back to the extrusion.

## 8.3 Global Adjustment of the Cutting Spring Pressure

- 8.3.1 This adjustment has been set at the factory. If for some reason you find it necessary to make this adjustment, here are the steps:
- 8.3.2. Remove all cutting tool holders from the cutting cart.
- 8.3.3. The spring tension adjustment nut is located between the bearing tubes on the very bottom of the cutting cart. This adjustment is best done if the

# Onyx 90 Media Cutter

bottom of the cutting cart is elevated. You should have an assistant securely hold the cart at that elevation. Do not try to hold it and adjust by yourself.

8.3.4. Using a 7/16" nut driver or deep-well socket, reach behind the cart from the right hand side and slide the tool onto the spring tension adjustment nut.

8.3.5. If more tension is desired, tighten the spring tension adjustment nut. If less tension is desired, loosen the spring tension adjustment nut. This nut has an internal nylon locking ring to keep it from moving. So once you move it, the nut will stay in that position until you move it again.

8.3.6. Insert the glass tool into the cutting cart and try the new pressure. Adjust as required.

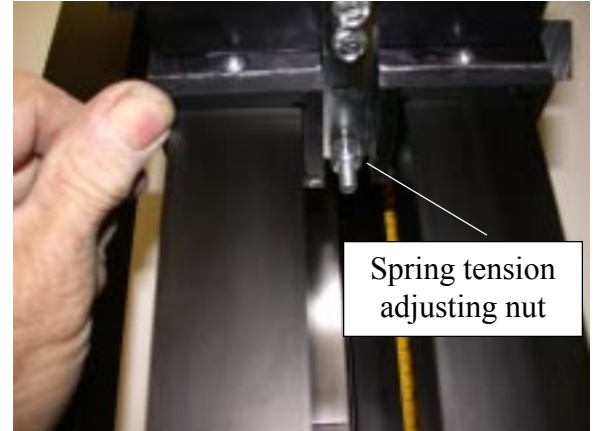

## 8.4 Adjustment for Depth of Cut

This adjustment has been set at the factory. If for some reason you find it necessary to make this adjustment, here are the steps:

8.4.1 Look at the handle located on the cutting cart. Notice a lower handle retaining screw and an

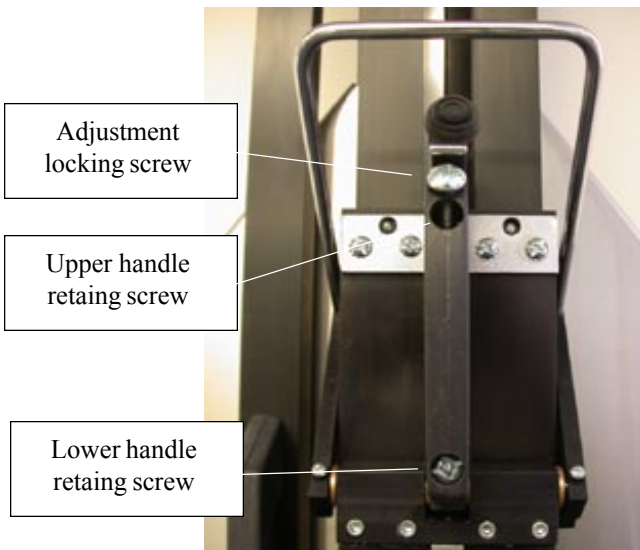

upper handle retaining screw.

These two screws are counter-bored into the handle and attach the handle to the cutting cart.

Just above the upper handle retaining screw, you will see a third screw. This third screw is the "adjustment locking screw."

8.4.2 Loosen the adjustment locking screw until you can insert a largephillips head screwdriver into the slot of the upper handle retaining screw.

8.4.3 Insert the glass cutting tool onto tool pivot arm.

8.4.4 Release the handle with the thumb release and allow the glass cutting tool to bottom.

8.4.5 With the handle in the released or bottomed position, rotate the upper handle retaining screw clockwise to decrease the depth. Rotate the upper handle retaining screw counterclockwise to increase the depth. After you have made the adjustment to the cutting depth, be sure to push the handle in so that it is

# Onyx 90 Media Cutter

- 8.4.6 resting on the new adjusted stop distance.  
Tighten the adjustment locking screw.

## 9.0 Troubleshooting

- 9.1 When cutting glass, the glass cutter jumps or skips.

Causes: Dirty glass  
*Clean glass*  
Worn glass wheel  
*Rotate to new wheel*  
Too little pressure  
*Adjust by applying slight pressure with hand*  
*Make global adjustment -not likely-*  
The glass cutting wheel rotates on an axle. There maybe shards of glass between the glass cutting wheel and the wheel axle. This debris can cause the glass cutting wheel to not rotate freely.  
*Lubricate axle and glass wheel area.*



- 9.2 When cutting glass, chipping or flaking occurs.

Causes: Too much pressure  
*You maybe applying too much pressure on the handle.*  
*Pull back on the handle during cut.*  
*Too much pressure will shorten wheel life.*  
*Never score twice.*

- 9.3 When cutting plastic, it skips and or chatters.

Causes: Scoring too fast  
*Slow down the stroke speed*  
Scoring tool broken  
*Rotate cutter if you have not done so previously*  
Too much pressure  
*Reduce pressure slightly on handle*  
Not using media clamp  
*Use media clamp*

- 9.4 When cutting mat board, the mat board buckles.

Causes: Mat board not clamped

# Onyx 90 Media Cutter

*Use media clamp*  
Blade too dull  
*Change to new blade*

9.5 The cut edge of mat board is frayed

Causes: Dull mat cutting blade  
*Change to new blade*  
No slip sheet under media being cut  
*Use slip sheet*

9.6 When I make my cuts, the dimensions are incorrect

Cause: The measuring scale is off  
*Recalibrate the measuring scale – See Section 8.2*

9.7 The cut edge is not square - not a 90 degree cut.

Causes: Debris between the media and cutting bed  
*Remove debris*  
Cutting bed is not perpendicular to vertical extrusion.  
*quare the cutting bed -Not likely-*

***You are very important to us. Our success depends on your satisfaction. If you are having any problems or have any comments, please call us at 800-334-9060.***

# Onyx 90 Media Cutter

## Onyx 90 Product Registration Card

Registering your Onyx 90 media cutter is essential to ensure that you validate your warranty and receive all the benefits of product ownership.

Date of Purchase \_\_\_\_\_  
First Name \_\_\_\_\_  
Last Name \_\_\_\_\_  
Street Address \_\_\_\_\_  
Street Address \_\_\_\_\_  
City, State, Zip \_\_\_\_\_  
Email Address \_\_\_\_\_  
Phone Number \_\_\_\_\_  
Serial Number \_\_\_\_\_

Mail to Professional Picture Frame Equipment  
441 South Whitted St.  
Hendersonville, NC 28739



**Fastest tool change in the industry**  
**Anodized aluminum and stainless steel**  
**Oil impregnated bronze bushings**  
**FedEx / UPS shippable**  
**Production stop included**  
**Cutting depth 5/8 inches**  
**Built-in mat board and acrylic clamp**

**Cuts mat board, gator board, glass and acrylic**  
**Built to last a life time**  
**Ultra high molecular weight polyethylene**  
**Stainless steel wall mounting brackets**  
**Five year warranty**  
**Made in USA**  
**Carbide plastic cutter**